

## Research on Wushu Actions and Techniques Based on a Biomechanical Sensor System

Xiaohong Wang<sup>1</sup>, Chuan Zhi<sup>2</sup>, Qiang Wang<sup>3</sup>

<sup>1</sup>Physical Education Department of Southeast University  
Nanjing, Jiangsu, China  
E-mail: [w\\_xiaohong113@sohu.com](mailto:w_xiaohong113@sohu.com)

<sup>2</sup>The Teaching and Research Section of Traditional Sports  
Nanjing Sports Institute  
Nanjing, Jiangsu, China  
E-mail: [13913881001@139.com](mailto:13913881001@139.com)

<sup>3</sup>Institute of Physical Education, Shenyang Normal University,  
Shenyang, Liaoning, China  
E-mail: [wangq\\_edu@sohu.com](mailto:wangq_edu@sohu.com)

Received: December 01, 2016

Accepted: June 12, 2017

Published: June 30, 2017

**Abstract:** Wushu actions and techniques is an index reflecting the differences in physical quality, basic skills and performance level between athletes. But the gap narrows because of the rapid development of sports events with high difficulty and aesthetic values. Thus, it is urgent to improve Wushu techniques and create new ones. This study measured and quantitatively analyzed Wushu actions and techniques using a biomechanical sensor and biomechanical theory, aiming to provide scientific guidance and technical support for the promotion and improvement of Wushu level and the enhancement of the visual sense and competitiveness of Wushu. In the study, the plantar pressure of a flying kick was measured using a Polyvinylidene Fluoride (PVDF) insole plantar pressure sensor. The data analysis suggested that the heel had little influence on take-off jumping and the load borne by the sole was the largest, which provided a quantitative basis for the innovation and beautification of the take-off action of the jumping kick and also suggested the design of the plantar pressure sensor was reasonable and feasible.

**Keywords:** Plantar pressure sensor, Quantitative analysis and measurement, Wushu level.

### Introduction

Specialized agencies responsible for developing Wushu exercise have been established in China, for example, the Wushu Department, established by the National Athletic Committee in the 1950s and the current Sports Administration Center of General Administration of Sport of China. Classifying Wushu as a competition event lays a foundation for the development of Wushu and is also a historical contribution [3, 10, 13, 16]. The perfect innovation of Wushu actions and techniques is an index for measuring a Wushu event. Analyzing Wushu action level with biomechanics has certain theoretical significance and reference value and the major actions involved include shadowboxing actions, Sanshou actions and Wushu routines [2, 6, 7]. Xu and Jiang [22] analyzed the punching characteristics of shadowboxing in the perspective of mechanics according to the three elements of force. Mosher [18] qualitatively analyzed the mechanical process of tai chi push hands tactics. Yao [23] made a biomechanical analysis on side kick of Wushu Sanshou based on  $F = Ma$  and the direction of force. Through comparing and analyzing the similarity and difference of the side kick action of four Sanda athletes, Fan [8] found that the striking force could be strengthened when the muscles involved in the action were at the same plane. Chu [5] explained the weight shifting, abdominal curl and waist

holding of back sweep based on law of conservation of moment of momentum and the concept of frictional force. Imamura and John [11] considered shifting weight to the left leg and closing body to the center of rotation axis could reduce inertia, increase rotation speed, reduce the friction with ground, and ensure speed of leg sweep. The above cases were all qualitative studies on Wushu actions based on the basic theories of biomechanics [4, 15]; however, data were not sufficient. Through referring to some studies concerning gait and action analysis [13, 21], this study made a quantitative analysis on the take-off action of a jumping kick using a plantar pressure sensor, aiming to provide a quantitative basis for the innovation and beautification of the action.

### **The analysis of a jumping kick**

The jumping kick as one of Wushu routines mainly includes run-up, take off, action in the air and landing and buffering in the perspective of biomechanical technology.

(1) Run-up: The run-up is the most important part in a jumping kick. Its speed determines bounce altitude and technical integrity. Sportsmen usually improve speed, take-off strength and bounce altitude by combining run-up with an arm swing.

(2) Take-off: To obtain a relatively large impulsion when rising high into the air, the center of gravity needs to be lowered to make the hip, knee, ankle joint and digit muscle group which looks like compressed spring to extend violently while taking off. At the moment of extension, a counter-acting force larger than gravity can be got, which can increase upward accelerated speed and bounce altitude.

(3) Action in the air: A jumping kick is mainly made in the air. The upper part of the body leans forward and depresses to increase the upward swing height of the two legs. Depression is usually made when the two legs swing to the horizontal level; early depression will affect the upward swing of the two legs. The upper part of the body should keep a certain angle with the vertical level, which is beneficial to offset the moment of momentum when the upper part of the body claps instep and depresses forward. A jumping kick mainly relies on the explosive power and coordination ability of abdominal muscle, waist and legs.

(4) Landing and buffering: Landing is the last step of the action. When the body lands on the ground, the muscle groups of legs, hip, knee and ankle joint are bended slightly to buffer the pressure brought by gravity and accelerated speed.

### **Design of an polyvinylidene fluoride plantar pressure sensor**

The design of an polyvinylidene fluoride (PVDF) piezoelectric thin-film sensor as a biomechanical sensor can detect the change of pressure on the sole of the feet. The observation of the change can help guide Wushu techniques.

#### *Property analysis of the PVDF piezoelectric thin-film sensor*

The PVDF piezoelectric thin-film is a kind of light, soft and thin polymeric membrane which can bend millions of times. When power supply condition is limited, the PVDF piezoelectric thin-film can produce a small amount of energy in some specific structures and work passively. Ordinary piezoelectric thin-film is sensitive to pressure; therefore, it can be used as a dynamic strain sensor. When there is a deformation, the surface of the film electrode will produce an electric charge, which is associated to deformation proportion. When a small force is exerted vertically on the PVDF piezoelectric thin-film, large induced stress will be produced horizontally. But if the same force is exerted on the PDVF piezoelectric thin-film in

a large area, the produced stress will be dispersed. Thus, it can be concluded that piezoelectric thin-film is quite sensitive to dynamic stress. In the detection of subtle signals, the PVDF piezoelectric thin-film changes in parts per million of its length and the lowest response frequency can be 0.1 Hz; therefore, it is quite suitable for the measurement of dynamic plantar pressure of Wushu athletes [1, 17].

### *PVDF piezoelectric thin-film sensor based equivalent circuit*

Electric charge will be produced on the surface of a dielectric medium when an external force is exerted on it in a certain direction to make it deform; when the external force is removed, the dielectric medium will recover to the uncharged state. It is called positive voltage effect [20].

Under the effect of an external force  $F$ , both sides on the surface of the PVDF piezoelectric thin-film will produce a pair of electric charges; PVDF thin-film at the moment is equivalent to a capacitance. But actually, the PVDF thin-film produces surface charges rather than real charges. Only when amplified by the charge amplifier can charge signals be transformed to voltage signals, which can facilitate the collection and measurement of sensors. The schematic diagram is shown in Fig. 1.

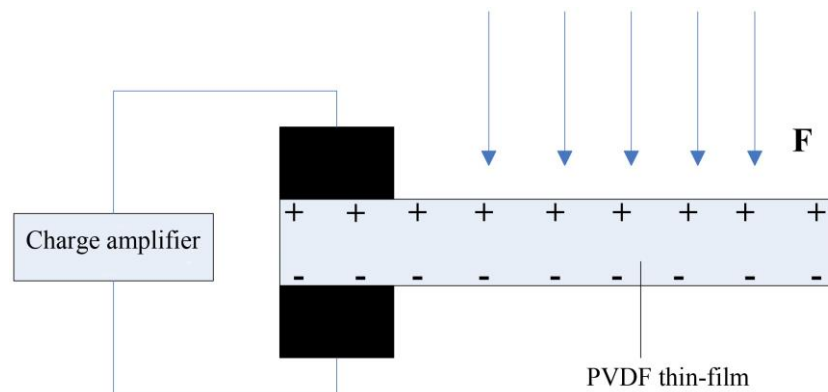

Fig. 1 The schematic diagram of the the PVDF sensor

The capacitance of the PVDF thin-film  $C = \frac{\varepsilon A}{H}$ ;  $\varepsilon$  stands for the dielectric constant of the piezoelectric thin-film material,  $A$  stands for the area of thin film, and  $H$  stands for the thickness of thin film.

Fig. 2 shows the different axial directions of the piezoelectric thin-film. Direction 1 is the thickness direction of the piezoelectric thin-film, direction 2 is the width direction of the PVDF piezoelectric thin-film, and direction 3 is the length direction of the PVDF piezoelectric thin-film. According to the position of the PVDF piezoelectric thin-film, direction 1 is the forced direction.

### *Design of an insole PVDF piezoelectric sensor*

To ensure the measurement accuracy of plantar dynamic force and the wearing comfort of athletes, the sensor was designed as a sandwich multilayered structure. The PVDF piezoelectric thin-film sensor was embedded into a soft substrate in a shape of an insole to avoid errors caused by excessive deformation and improve the accuracy of data [9].

When the Wushu athlete did the action of a jumping kick, the areas on the sole of the foot as shown in the figure are responsible for adjusting the balance. The measurement of plantar pressure information in those areas can provide a quantitative basis for the improvement of the action. Thus, thin-film piezoelectric sensors were installed on the ten points indicated in Fig. 3.

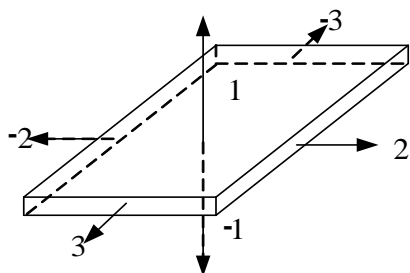

Fig. 2 The schematic diagram of stress of a piezoelectric sensor



Fig. 3 The setting points of sensors

## Overall design of the sensor

### *Measurement principles of the sensor*

The acquisition and measurement principles of plantar pressure signals were as follows. Firstly, pressure signals were transformed to electrical signals through a piezoelectric sensor. Then, the signals were sent to the micro-control analogue-to-digital (A/D) conversion circuit after being amplified by a charge amplifier. Analog electronic signals were transformed to digital signals. Finally, the data were sent to personal computers through wireless digital communication technology.

PVDF thin-film sensors had a relatively high resistance. Usually, when output signals were sent to a detection circuit, the detection circuit could only accept low-impedance input. Thus, a three-level operational amplifying circuit was adopted in the design of a charge amplifier. The circuit was composed of three computational amplifiers. Only when the values of the resistances were set as shown in Fig. 4, can the amplification be the maximum.

### *The hardware structure of the sensor*

The measurement system was designed based on sensor technology, micro-processor technology and ZigBee network communication technology. The specific hardware frame diagram is shown in Fig. 5.

The internal system circuit of the measurement instrument composed of sensors and other components adopted STC89LE54RD+ as the microcontroller; the A/D conversion channel of STC89LE54RD+ could transform pressure signals into digital signals [19]. CC2420 was adopted as the chip of the wireless data transceiver of a ZigBee module to package and transmit data, and the communication with the computer was realized through a Rs-232 serial port [12].

### Analysis of the experimental results

A Wushu athlete who weighed 60 kg and had normal foot anatomical structure, physiological function and good health condition was selected as the research subject. Firstly, the plantar pressure test system was connected and debugged.

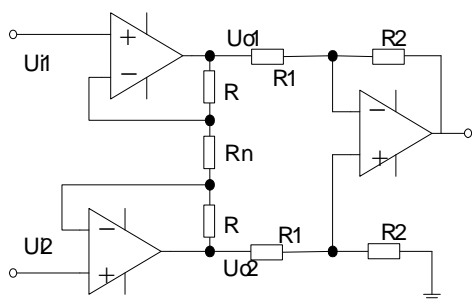

Fig. 4 The amplification circuit inside the charge amplifier

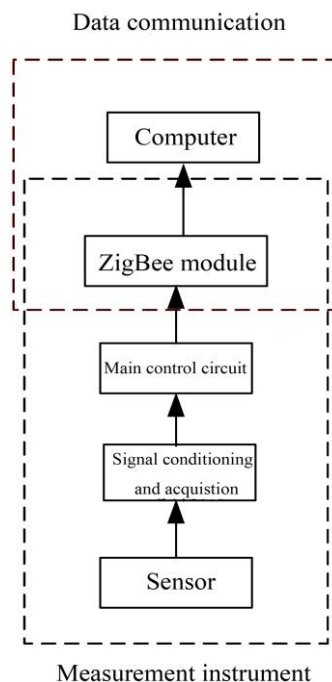

Fig. 5 The hardware frame diagram

The testing area for the test subject was within 100 m away from the measurement instrument to ensure the stability of the testing results. In formal testing, the plantar data of the right foot was collected when the research subject did the action of a jumping kick. After the sorting of the experimental data, the parameter values of the take-off jump were obtained, as shown in Table 1.

Table 1. Parameter values in the process of a take-off jump

Area	ST (ms)	ET (ms)	%C	FMAX (N)	I (Ns)	CA (cm <sup>2</sup> )	PMAX (N/cm <sup>2</sup> )	LR (N/s)
1	0	118	49	228.3	8.3	21.8	10.5	48.49
2	0	114.7	59	194	8.5	25.5	7.6	Inf
3	10.7	199	77	155.6	16.1	51.4	3	3.95
4	17.1	212.4	80	24.7	1.3	7.9	3.1	1.51
5	13.8	229.5	89	86.4	13	10.9	13.6	3.3
6	22	234.7	87	142.5	18.8	11.2	12.7	2.09
7	34	239.3	84	188.4	24.1	13.9	7.9	3.01
8	43.6	238	80	172.4	20.4	19.9	8.7	3.25
9	57.2	243.3	77	39.1	5	7.5	5.2	1.08
10	36.9	243.3	100	243.4	32.6	30.4	8	3.86

ST (Sensor time) refers to the time points of specific areas beginning to land; ET (End time) refers to the time points of specific areas leaving the ground; %C (%Content) refers to the proportion of the contacting time of a specific area in the whole gait stage; FMAX stands for the peak pressure value of the detection area; I (Impulse) stands for the impulse of a specific area;

CA (Contact area) stands for the contacting area of a specific area; P<sub>MAX</sub> stands for the maximum pressure intensity of the detection areas; LR (Locate rate) stands for the pressure change rate of a specific area.

The time points of specific areas beginning to land and the time points of specific areas leaving the ground suggested the impulse of different areas in the course of the action.

The maximum peak pressure intensity F<sub>MAX</sub> was found in area 10, i.e., the propodeum, indicating pushing off the ground with the sole promoted the action of backward somersault. If the peak value appeared in the other areas, the counterforce given by the ground would be weakened.

The contacting time of the area 10 accounted for the largest proportion in the whole take-off process, indicating the major force application area in the take-off jump stage of the jumping kick was area 10. The analysis of the parameters of area 10 suggested that the athlete should leave the ground immediately after area 10 landed in order to obtain larger acceleration on the earth and reduce force loss.

The area with the largest pressure intensity value was the area with the largest planar load and also the area which was more likely to be injured. The area was at the fourth metatarsal bone (area 5 in Fig. 4). The fourth metatarsal bone is fragile and should be taken care of to avoid injury.

The largest value of impulse appeared in area 7, suggesting that the power motivating area 7 to leave the ground was the largest. The larger the impulse was, the better the action was completed.

The change rate of pressure of specific areas could reflect the injury degree of different areas in the whole Wushu action. The change rate of pressure of different areas was 1, 3, 10, 5, 8, 7, 6, 4, 9 and 2, from high to low. The higher the change rate, the higher the risks of injury. Thus, the change rate could be reduced properly; in order words, there could be a short pause between actions.

## Conclusion

This study measured the plantar pressure in the action of a jumping kick using a PVDF insole plantar pressure sensor. The analysis of experimental data suggested that the influence of the heel on the take-off jump was quite small. Thus, in the beginning of the action, the contact area of the heel with the ground could protect the heel without affecting the take-off jumping. The load of the sole was the largest during the take-off; therefore, more attention should be paid to avoid injury in training and ensure the quality of the action. Database basis was difficult to form due to the small number of research subjects in this study. This work aims to provide a feasible support for further research in the future.

## References

1. Ali R., D. R. Mahapatra, S. Gopalakrishnan (2010). Time Domain Characteristics of Electrical Measures for a Piezoelectric Thin Film to Identify Defects in the Substrate, *Structural Health Monitoring*, 9(2), 173-192.
2. Bujak Z., M. V. Muntean, D. Gierczuk (2014). The Hierarchy of Professional Activities of Martial Arts and Mixed Martial Arts Coaches, Ido Movement for Culture, *Journal of Martial Arts Anthropology*, 14(2), 29-35.

3. Cai L. M. (2012). Sports Biomechanical Analysis of Sanda Side Kick Attacking Legs in Competitive Wushu, *Wushu Science*, 5, 52-54.
4. Chen Y. F. (2016). Analysis on the Cultivation of Students' Lifelong Physical Education Consciousness in Wushu class, *Journal of Mudanjiang College of Education*, 7, 124-125.
5. Chu F. G. (2013). Biomechanical Analysis and Teaching Methods for the Movement of the Rear Sweep Legs, *New Curriculum*, 12, 159-160.
6. Delamont S. (2013). Performing Research or Researching Performance? The View from the Martial Arts, *International Review of Qualitative Research*, 6(1), 1-18.
7. Devita P., W. A. Skelly (2012). Effect of Landing Stiffness on Joint Kinetics and Energetics in the Lower Extremity, *Medicine & Science in Sports & Exercise*, 24(1), 107-108.
8. Fan S. (2006). A Biomechanical Analysis of the Chinese Wushu Sanda Side-kick as Performed by Elite Male Wushu Sanda Competitors, *24 International Symposium on Biomechanics in Sports 2006*, Salzburg, Austria, 1, 497-500.
9. Gatt A., N. Chockalingam, O. Falzon (2013). Sagittal Plane Kinematics of Passive Dorsiflexion of the Foot in Adolescent Athletes, *Journal of the American Podiatric Medical Association*, 103(5), 394-399.
10. Huang X. (2016). The Basic Way of the Development of Wushu in Middle School Physical Education, *Sporting Goods & Business*, 6, 55-56.
11. Imamura R., B. Johnson (2003). A Kinematic Analysis of a Judo Leg Sweep: Major Outer Leg Reap-osotogari, *Sports Biomechanics*, 2(2), 191-201.
12. Jin J., M. Palaniswami, B. Krishnamachari (2012). Rate Control for Heterogeneous Wireless Sensornetworks: Characterization, Algorithms and Performance, *Computer Networks*, 56(17), 3783-3794.
13. Kumar B. A. (2017). Classification and Clustering of Parkinson's and Healthy Control Gait Dynamics Using LDA and K-means, *International Journal of Bioautomation*, 21(1), 19-30.
14. Li C. L. (2016). On the Core Factors of Winning the Competition of Excellent Wushu Routine Athletes, *Journal of Guangzhou Physical Education Institute*, 4, 82-84.
15. Lou L. F., Y. T. Yang, Y. J. Li (2008) Preparation and Micro-fabrication of PZT Piezoelectric Thin Film for Micro-sensor, *Piezoelectrics & Acousto-optics*, 4, 453-455.
16. Madisyn J. A. (2012). Sport in Cambodia.
17. Mohammadi B., A. A. Yousefi, S. M. Bellah (2007). Effect of Tensile Strain Rate and Elongation on Crystalline Structure and Piezoelectric Properties of PVDF Thin Films, *Polymer Testing*, 26(1), 42-50.
18. Mosher H. (2011). Form and Function: Why Push-hands is Essential to the Practice of Taijiquan, *Journal of Asian Martial Arts*, 20(1), 94.
19. Redaelli N. G., R. Turchetta (2013). A Capacitive Displacement Measuring System for the Delphi Microvertex Detector, *Scientific Journal of Iranian Blood Transfusion Organization*, 24(3), 317-327.
20. Sworakowski J., U. Bielecka, P. Lutsyk, K. Janus (2014). Effect of Spatial Inhomogeneity of Charge Carrier Mobility on Current-voltage Characteristics in Organic Field-effect Transistors, *Thin Solid Films*, 571, 56-61.
21. Xie H. L., K. L. Chen, Y. Y. Yang, F. Li (2015). Artificial Leg Design and Control Research of a Biped Robot with Heterogeneous Legs Based on PID Control Algorithm, *International Journal of Bioautomation*, 19(1), 95-106.
22. Xu Y. J., Jiang Z. C. (2000). Mechanical Analysis and Application of Taiji Pushing Hands, *Journal of Physical Education*, 3, 111-113.
23. Yao C. H. (2003). The Mechanical Analysis of Wushu Side-kick and a Study of its Teaching Methods, *Journal of Hubei Sports Science*, 4, 468-469.

**Xiaohong Wang**E-mail: [w\\_xiaohong113@sohu.com](mailto:w_xiaohong113@sohu.com)

Xiaohong Wang comes from Ru Dong County, Jiang Su Province, China. She works as a lecturer in the Physical Education Department of Southeast University, Nanjing, Jiangsu Province, China. Her research directions are physical education teaching and sports training.

**Assoc. Prof. Chuan Zhi, M.Sc.**E-mail: [13913881001@139.com](mailto:13913881001@139.com)

Chuan Zhi comes from Su Yang, Jiang Su Province, China. He has got Master's degree and works as an Associate Professor in the Teaching and Research Section of Traditional Sports in Nanjing Sports Institute, Nanjing, Jiangsu Province, China. He is dedicated to studying physical education teaching and the national traditional sports. Now he is the Head of National Traditional Sports in Nanjing Sport Institute, and has some research on national traditional sports and traditional sports health culture.

**Qiang Wang**E-mail: [wangq\\_edu@sohu.com](mailto:wangq_edu@sohu.com)

Qiang Wang was born in January, 1980. He is now working in the Institute of Physical Education in Shenyang Normal University, Liaoning, China. He is a graduate student, National First Class Athlete and National First Grade Referee. He once taught Wushu in Sendai University in Japan for five years and led the team to participate in the National Wushu Competitive Level Competition where they won the first prize. He has published 10 papers and won Liaoning Teaching Achievement Award, Provincial Excellent Course Award and Provincial Teaching Team Award.



© 2017 by the authors. Licensee Institute of Biophysics and Biomedical Engineering, Bulgarian Academy of Sciences. This article is an open access article distributed under the terms and conditions of the Creative Commons Attribution (CC BY) license (<http://creativecommons.org/licenses/by/4.0/>).